

Online Double Conversion UPS

# **Falcon x5**

UPS 60-80-100-120-160-200-250-300KVA



# Falcon x5

UPS 60-80-100-120-160-200-250-300 kVA

Fuji Electric's Falcon X5 Series is a unique and innovative UPS with competitive benefits of low ownership cost, high efficiency and is designed to operate in harsh environments with higher availability.

## Highlights of Falcon X5 UPS at a Glance

### Flexibility

- Common battery option for optimized selection of Battery for multiple UPS in parallel or Independent Configurations
- Wide input voltage from +20% to -40%
- Genset compliant with adaptive progressive walk-in and rectifier delay start options
- 3 Phase 3 wire rectifier fully compatible with existing infrastructure
- Compatible with all types of industrial loads including regenerative loads
- Parallel upto 8 units for capacity or redundancy

### Reliability

- Operating temperature of 0-40°C with special attention in component selection and design to improve reliability
- Input Phase sequence correction provided as standard
- Advanced battery management techniques to improve battery life with three stage charging and auto equalizing charge at pre-defined intervals.

### Total Cost of Ownership

- Efficiency of upto 95% in online double conversion mode of operation with in-built isolation transformer
- Intelligent Eco Mode of Operation with an efficiency of upto 99%



### Applications

- Engineering Industry
- Automotive and Auto Ancillaries
- Electronics Manufacturing
- Process Industry
- Food & Beverage Manufacturing
- Textiles
- Infrastructure
- Data Center

**Innovative & Unique Technology in UPS System**

Power walk-in and delayed start of rectifier gives the flexibility to install the UPS in all kinds of electrical infrastructure without any changes or oversizing of infrastructure.

The wide input voltage tolerance of the system (-40% to +20%) enables the UPS to work in on-line mode without using battery support for wide input voltage variations and even if there is an input phase reversal.

The UPS is fully accessible from the front side, no additional rear or side clearance is required, optimizing the area required for installation.

Inbuilt Output galvanic isolation transformer gives flexibility to connect two different input sources for rectifier and bypass mains. The transformer can also be connected either at the input, global output or on static bypass based on the installation requirement. This also gives the flexibility to adapt the downstream earthing system based on the installation requirements.

**Optimized & Flexible Battery Configuration**

Battery configuration can be adapted between 38-48 no's of 12V battery blocks which gives flexibility for optimized battery selection.

Battery configuration can be optimised with independent battery bank for each UPS or shared battery bank for multiple UPS which helps to optimize the selection of battery, space required for battery installation and the cost of installation.

**Advanced 3 Level Topology**

Falcon X5 series incorporates advanced 3 level technology. The Fuji Electric 3 level topology is more advantageous than conventional 3 level topology as losses can be reduced.

\* Transformer is Provided at inverter output as default.

**■ Rectifier Delay Start**

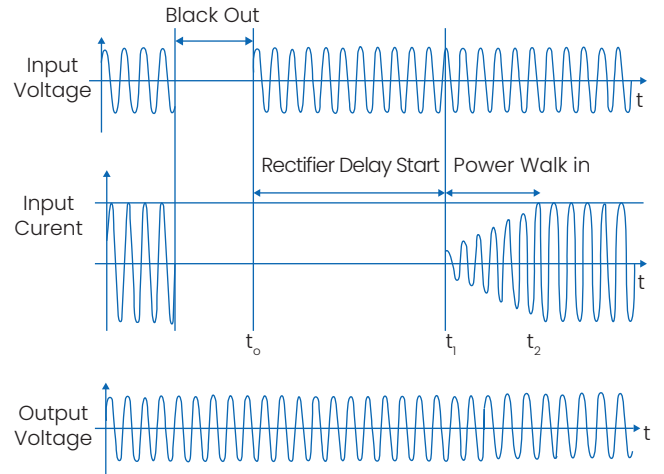

**■ UPS Block Diagram**

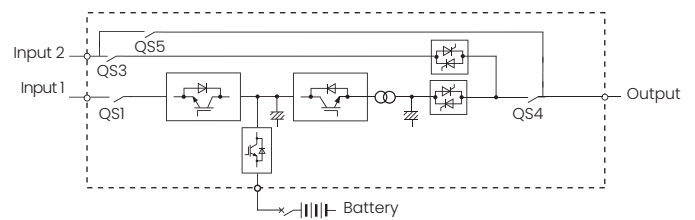

**■ Shared Battery Configuration**

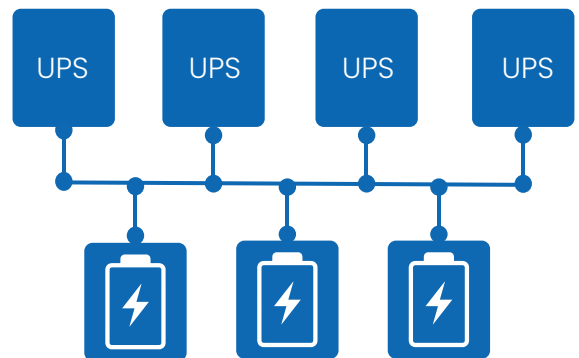

## Designed for Better Reliability, Maintainability & Serviceability

Falcon X5 series UPS is based on Fuji Electric's proven UPS technology and uses state-of-the-art power devices and power electronic technologies to offer better Reliability, Maintainability and Serviceability for large capacity UPS systems.

### Fault Tolerant Architecture

High inverter short circuit current handling capacity to clear downstream faults which occur between phase and neutral on load side upto 3.5 times nominal current for 100 milli seconds.

Advanced Three Phase Control enables handling of unbalanced three phase loads without any unbalance of output voltages.

### Advanced Parallel Configuration

Falcon X5 uses advanced Fuji Electric "Individual-Independent" parallel redundant architecture using looped communication method. This system has no single point of failure and each unit monitors all the other units with loop communication lines to ensure high reliability in parallel UPS systems.

### Advanced Thermal Management

Falcon X5 is designed to operate continuously at 40°C ambient temperature and uses forced air cooling with suction from the front and exhaust from the top. Special consideration in airflow design to isolate PCB from power devices for higher reliability. UPS is suitable to be installed in a well ventilated room without any air-conditioner.

### Ease of Access & User Friendliness

Falcon X5 maintenance requires only front access and back to back installation of UPS systems is possible to optimize space usage in UPS Rooms.

The Human Machine Interface (HMI) is intuitive and user friendly with a LCD screen and LED mimics. Easy identification of UPS working Status with the LED Glow bar.

- Green LED → Normal Working
- Yellow LED → Battery Mode of Operation
- Red LED → Critical Alarms

### Short Circuit Current of UPS

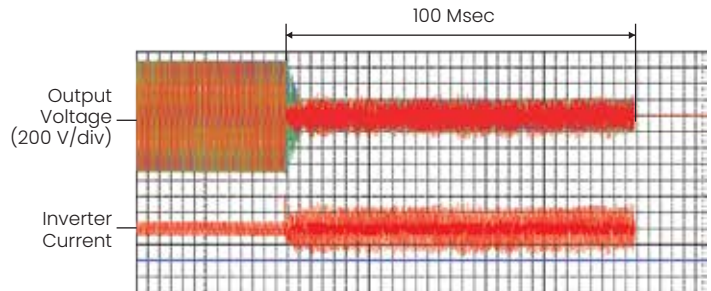

### Parallel Control Logic

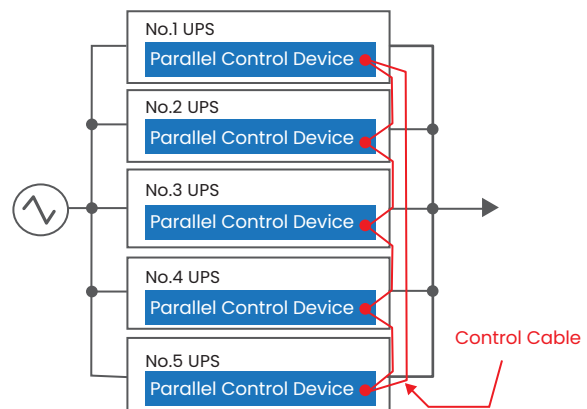

### Ventilation Arrangement of UPS Room

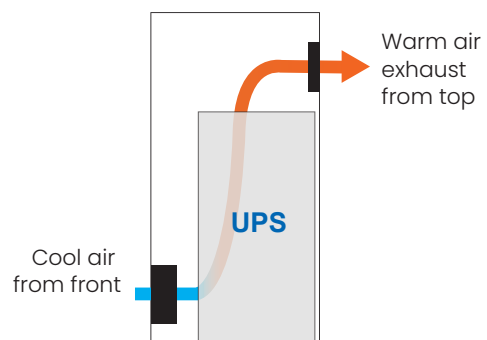

### User-Friendly HMI



MIMIC Display of UPS

LED Glow Bar

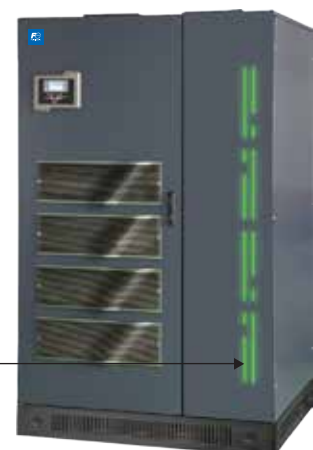

**Energy Efficient UPS System**

Falcon X5 is an online double conversion UPS fully meeting the requirements of IEC 62040-3.

The Eco mode operation of Falcon X5 guarantees an overall AC-AC efficiency of 99% and an efficiency of upto 95% in online double conversion mode of operation offering the highest efficiency, for UPS with in-built isolation transformer.

**Optimized Cost of Ownership**

Falcon X5 can be operated upto 40°C (Ambient Temperature) without any precision air conditioner as required by most UPS. This along with high efficiency helps large saving in CAPEX and OPEX cost associated with UPS.

Long life power Electronic grade capacitors are being used in the UPS which does not require the replacement of capacitors during its lifetime.

**Intelligent Eco Mode of Operation**

Falcon X5 has a intelligent high efficiency Eco Mode operations which can be enabled for energy savings (99% Efficiency).

The Firmware, tested to Indian power conditions monitors the quality of the input power, and enables the Eco Mode operations on bypass only when input power conditions are stable. Otherwise the UPS transfers back to double conversion mode in less than 5ms whereby the reliability of power is ensured to the critical load.

**■ Efficiency**

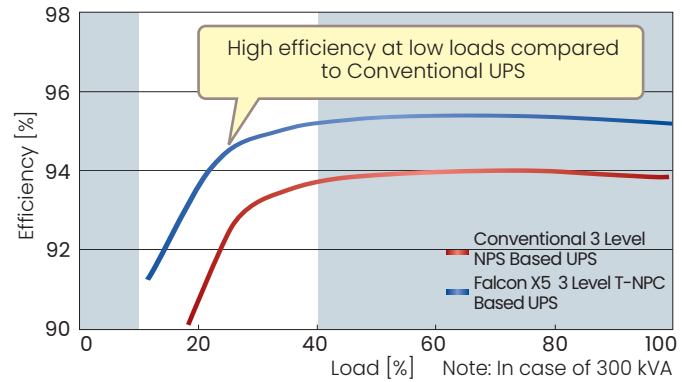

**■ Energy Saving**

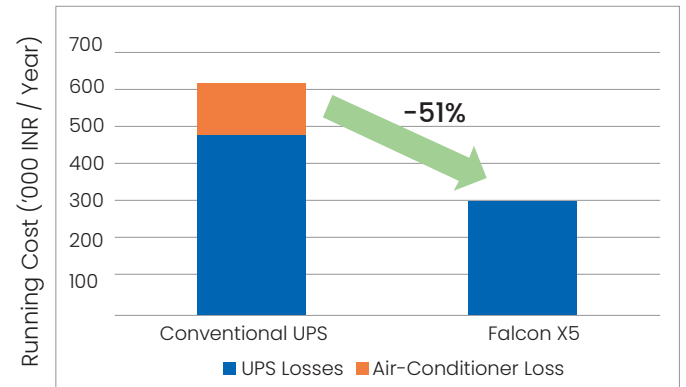

Calculation Conditions:  
Total annual running cost at Rs.7/kWh and 30% (100 kW) load

**■ Eco-Mode Operation of UPS**

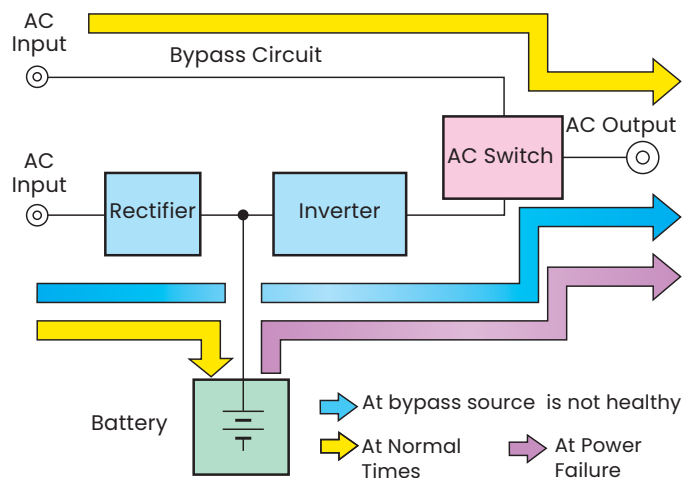

## Technical Specification

### Falcon x5

#### UPS 60-80-100-120-160-200-250-300 KVA

Model		Falcon X5							
Series	UPS Rating (KVA)	60	80	100	120	160	200	250	300
Input Parameters	Rated Voltage	400/415 V, 3-Phase + PE (380V Optional)							
	Rated Voltage Tolerance*	+20%, -40%* @ 400V							
	Rated Frequency	50/60 Hz ±10%							
	Current Harmonic Distortion (THD)**	<3% at 100% Load							
Bypass Parameters	Rated Voltage	400/415 V ± 10% (5-15% Selectable) 3-Phase + N + PE (380V Optional)							
	Rated Frequency	50/60 Hz							
	Connection	Separate From Mains Input							
Output Parameters	Rated Voltage	400 V, 3-Phase + N + PE (380/415 V Selectable)							
	Rated Frequency	50 or 60 Hz (Configurable)							
	Output Power Factor	0.9 PF							
	Voltage Variation - Static Load	±1%							
	Crest Factor	3:1							
	Voltage Distortion at Linear Load	≤2% (Typical)							
	Voltage Distortion at Non-Linear Load	≤3% (as per IEC62040-3)							
	Frequency Stability with Inverter Synchronized to the By-Pass Mains	±2% (Configurable from ±1% to ±6%)							
	Voltage Phase Shift with Balanced and Unbalanced Load	120° ± 1°							
	Overload Capacity	110% for 60 Mins, 125% for 10 Mins, 150% for 1 Min							
	Load Power Factor	0.7 Leading to 0.5 Lagging without De-rating							
	Efficiency	Up to 99% in Eco Mode and Upto 95% in Online Mode							
	Isolation Transformer	Inbuilt							
Battery Parameters	Number of Battery (12V) Blocks	40 Nos (Configurable from 38 to 48 Batteries)							
	Nominal Battery Voltage	480Vdc (Configurable from 456-576Vdc)							
	Compatibility	Compatible with SMF, Tubular, Ni-Cd, Li-Ion Battery							
Environmental Parameters	Ambient Temperature for the UPS	0 to 40°C (at Rated Input and Load)							
	Ingress Protection	IP20							
	Range of Relative Humidity	upto 95% max (without Condensing)							
	Maximum Operating Altitude	Up to 1000 above MSL							
	Storage Temperature	From 0°C to 60°C (UPS)							
	Acoustic Noise at 1m from Panel Front (Ref ISO3746)	< 68 dBA							
Other	Display	128x64 LCD Graphic Display with LED Mimic							
	Colors	RAL-9005 (Front Door), RAL-7016 (Other Sides)							
	Cooling System	Forced Air Cooling							
	Installation Site	Indoor							
	Cable Entry	Front - Bottom Entry							
	Communication Interface (Options)	Simple Network Management Protocol (SNMP), MODBUS-RTU , Dry Contacts							
Standards	Safety	IEC62040 - 1							
	Electromagnetic compatibility (EMC)	IEC62040 - 2							
	Performance	IEC62040 - 3							
Mechanical Parameters	Width (in mm)	800	800	800	800	840	1000	1200	1200
	Depth (in mm)	900	900	900	900	900	1000	1000	1000
	Height (in mm)	1700	1700	1700	1700	1800	2090	2090	2090
	Weight (in Kgs)	800	900	1000	1050	1280	1350	1680	1750

\*at part Load  
\*\*THDv @<1%

Front View

Side view

Note : Specifications are subject to Change

UPS Main Unit

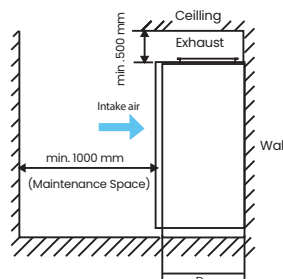
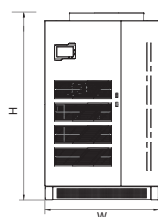



## Global Presence

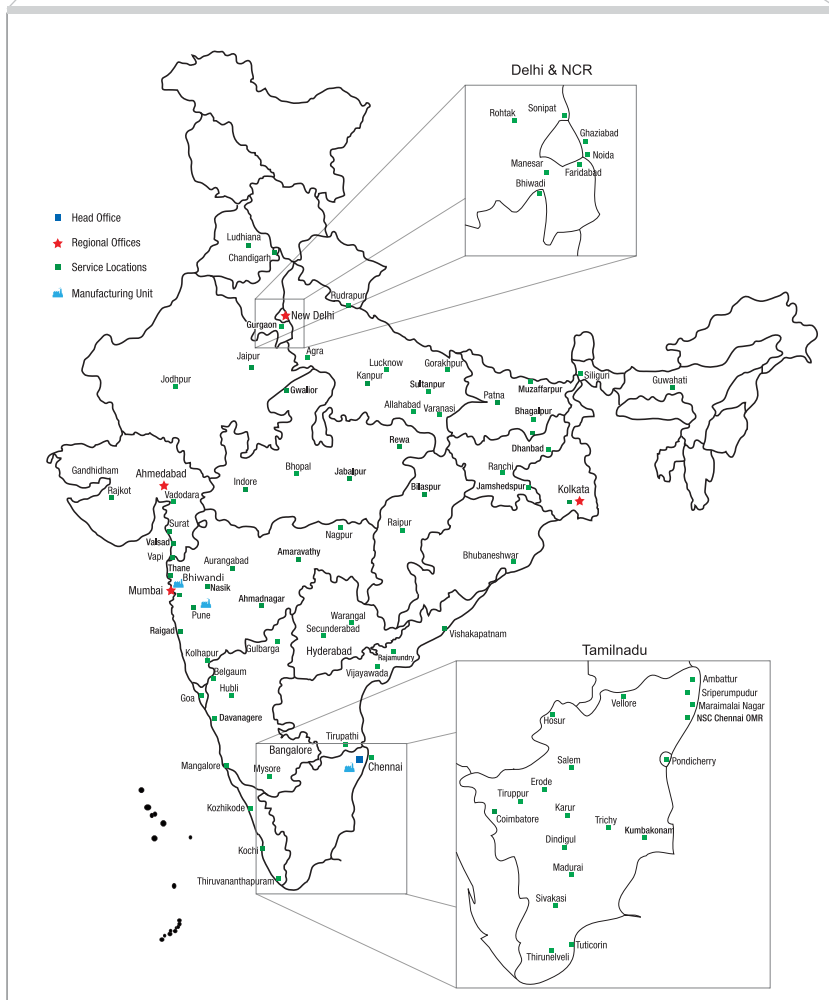
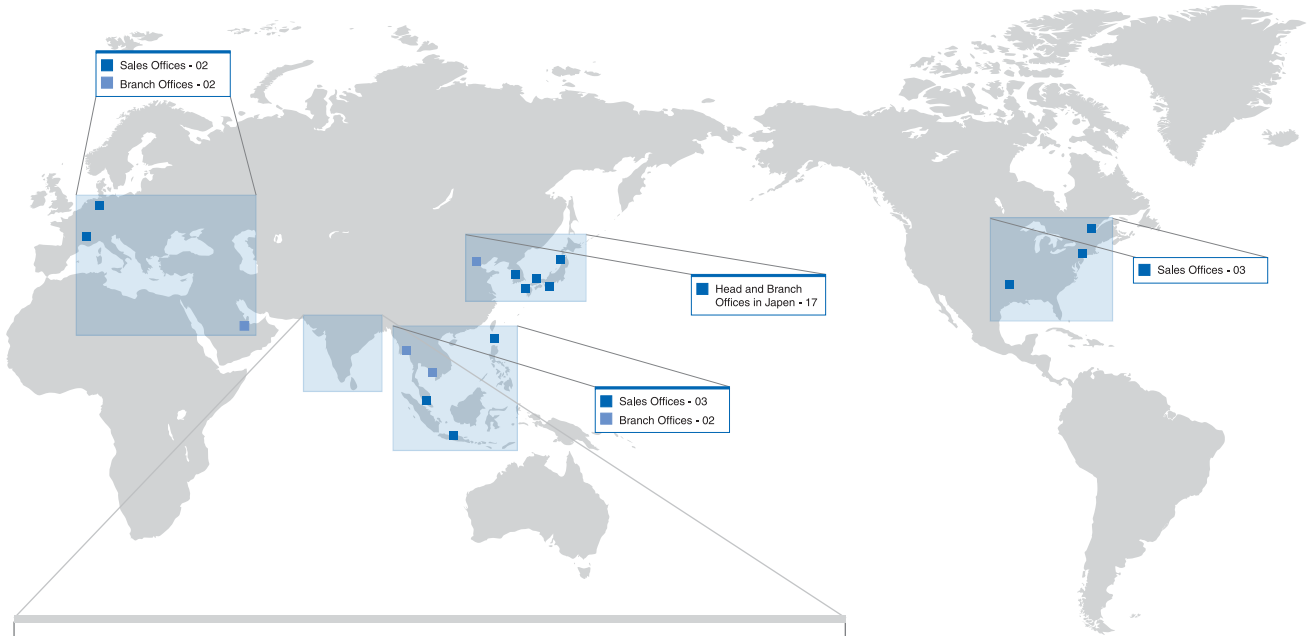

## Product Offerings

- Online UPS (1-800 KVA)
- Servo Controlled Voltage Stabilizer (Oil Cooled / Air Cooled)
- Active Harmonic Filter
- Static Transfer Switch
- Isolation Transformer
- Solar Inverter
- Medium Voltage / Low Voltage VFD
- Instrumentation
- Factory Automation
- Process Automation (PLC/HMI/SCADA)

## Service Offerings

- Comprehensive Annual Maintenance Contracts (CAMC)
- Annual Maintenance Contracts (Labour - AMC)
- AMC for Third Party Power Products
- Battery Replacement Services
- Power Audits
- Stabilizer Retrofits
- Rental UPS and Stabilizers
- Stabilizer Oil Replacement
- Remote Monitoring

## Fuji Electric India Pvt. Ltd.

(CIN:U31900TN1985PTCO11866)  
 119, 120, 120A, Electrical and Electronics Industrial Estate,  
 Perungudi, Chennai - 600 096, Tamil Nadu, India  
 ☎ +91 78100 09955  
 ✉ enquiry.fe@fujielectric.com  
 🌐 www.india.fujielectric.com



Scan QR code for Service support